

Sytem overview

HERMS design with fixed connections and 12 motorized ball valves.
 Can perform these steps without swapping hoses: fill with water, heat, mash in, mash, sparge, sparge out, whirlpool and cool, wort to fermentor, clean in place, drain system. All inputs and outputs to the system as a whole are manual, to prevent a mess on the floor.

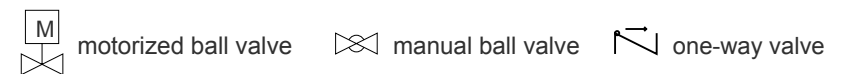

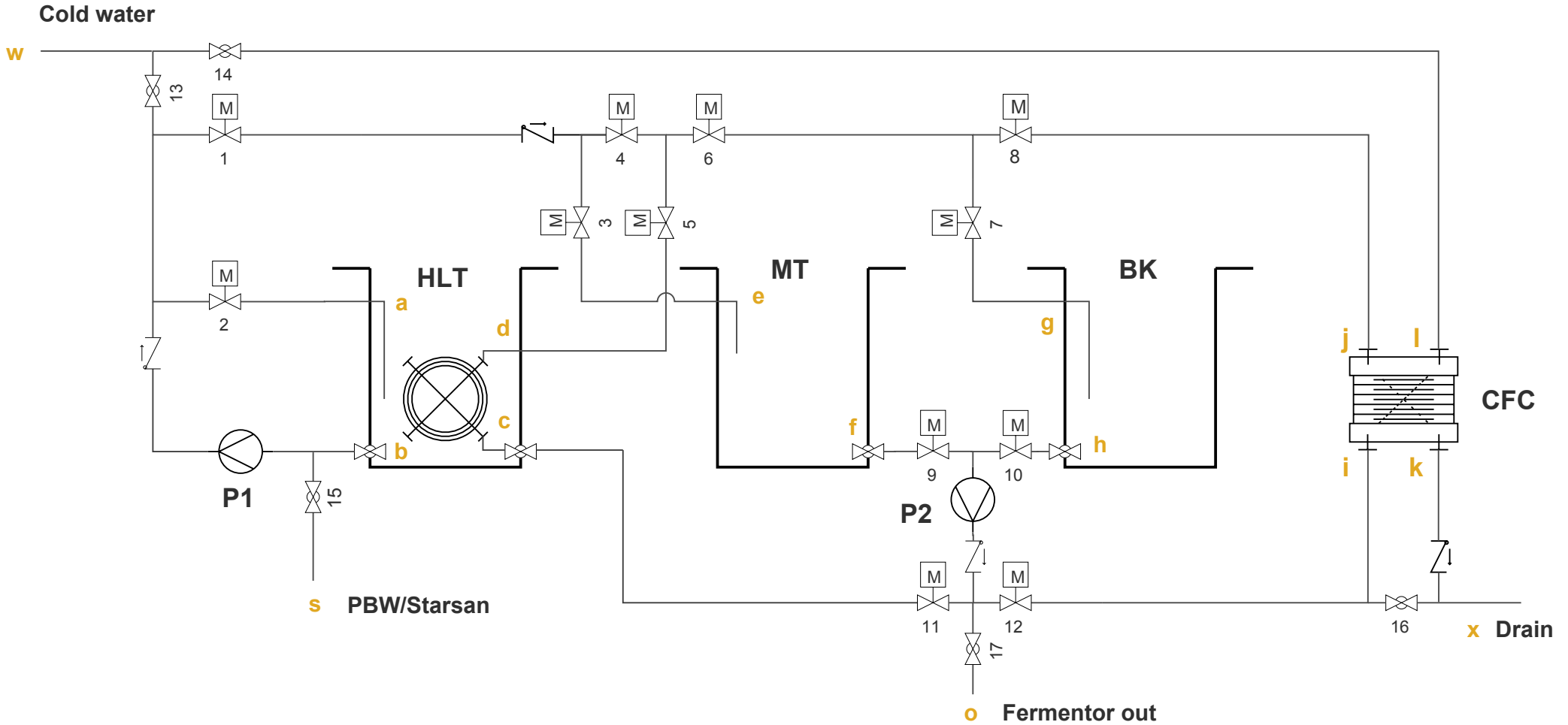

System overview

HERMS design with fixed connections and 12 motorized ball valves.

Can perform these steps without swapping hoses: fill with water, heat, mash in, mash, sparge, sparge out, whirlpool and cool, wort to fermentor, clean in place, drain system. All inputs and outputs to the system as a whole are manual, to prevent a mess on the floor.



motorized ball valve



manual ball valve



one-way valve

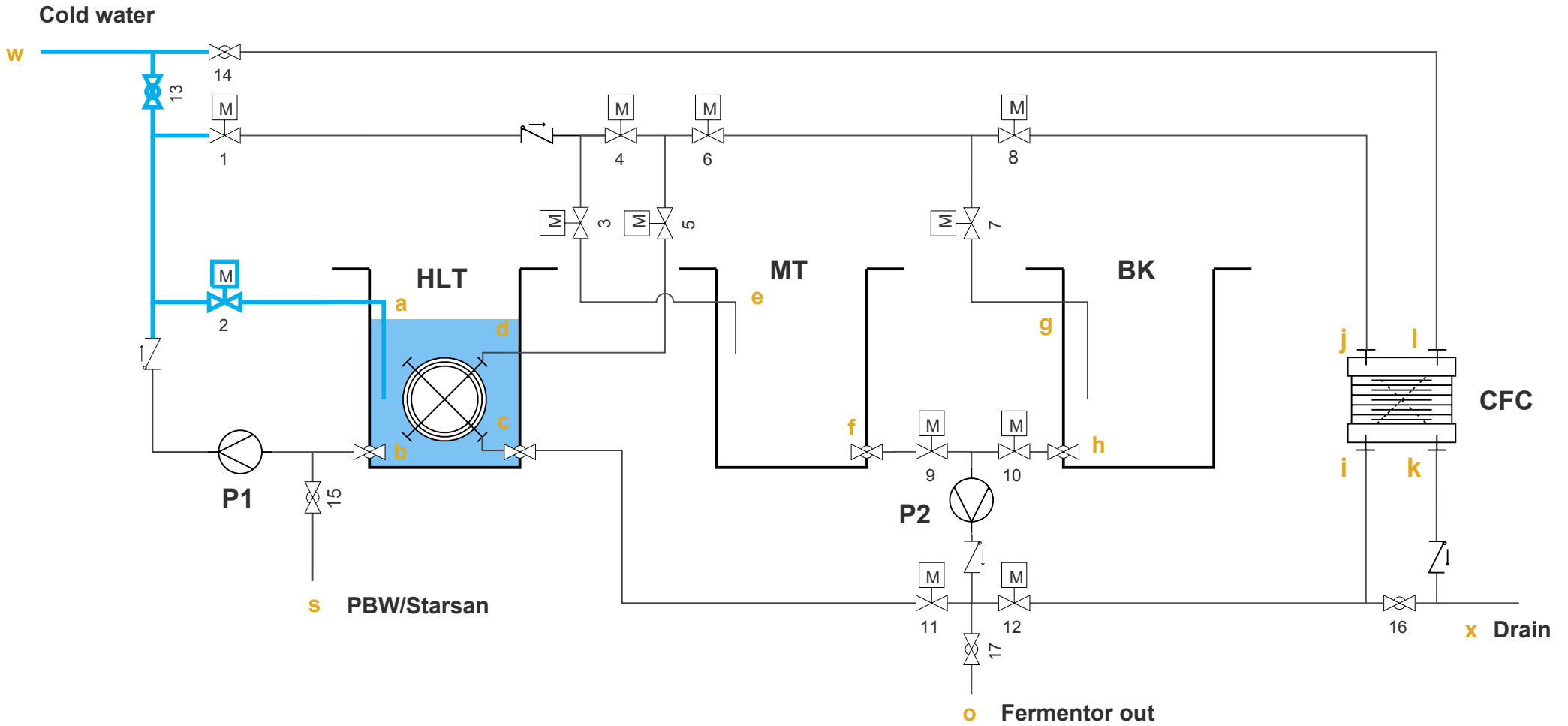

Fill HLT with cold water

From the cold water input, water can flow to the HLT, MT, BK and CFC. This is driven by tap pressure. In absence of pressure, move the water input before pump 1 at s.

To fill HLT, open manual valve 13. Let the system open valve 2 until full.

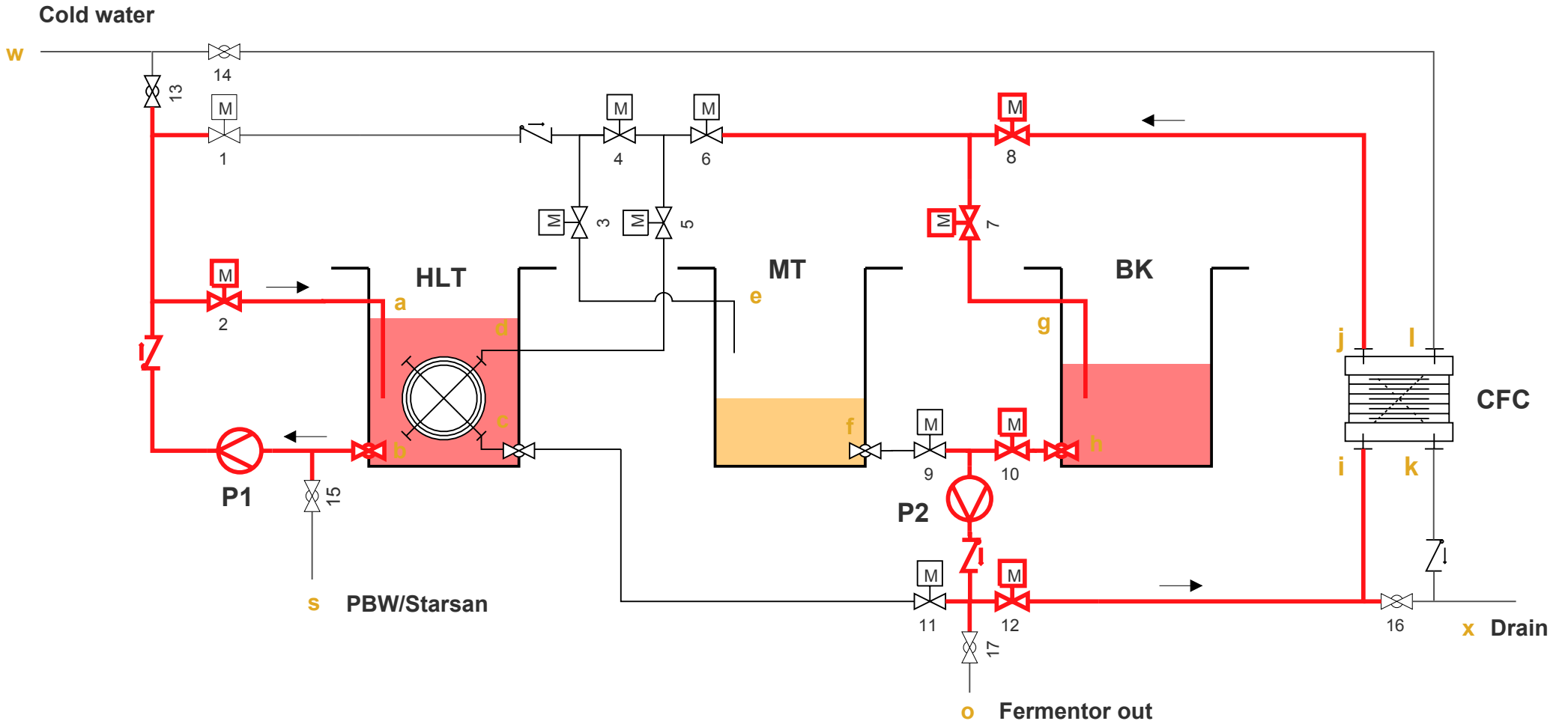

Heat HLT and BK

The HLT is heated to the first mash temperature, the BK is warmer to account for temperature losses later when grain is added. The BK and HLT are circulated while heating. In the mean time, grain is added to the MT.

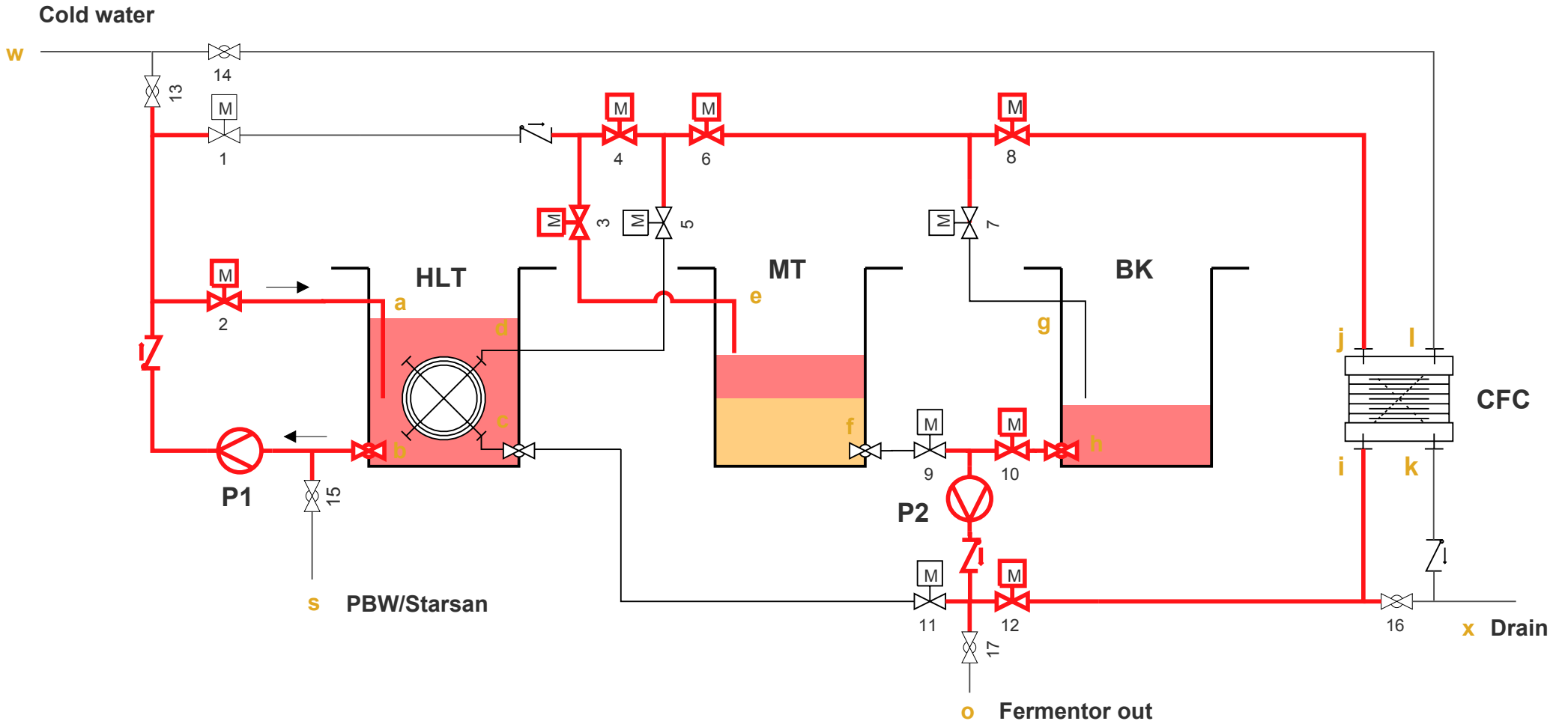

Strike / Mash in

Hot water from the boil kettle is pumped onto the grains in the mash tun.

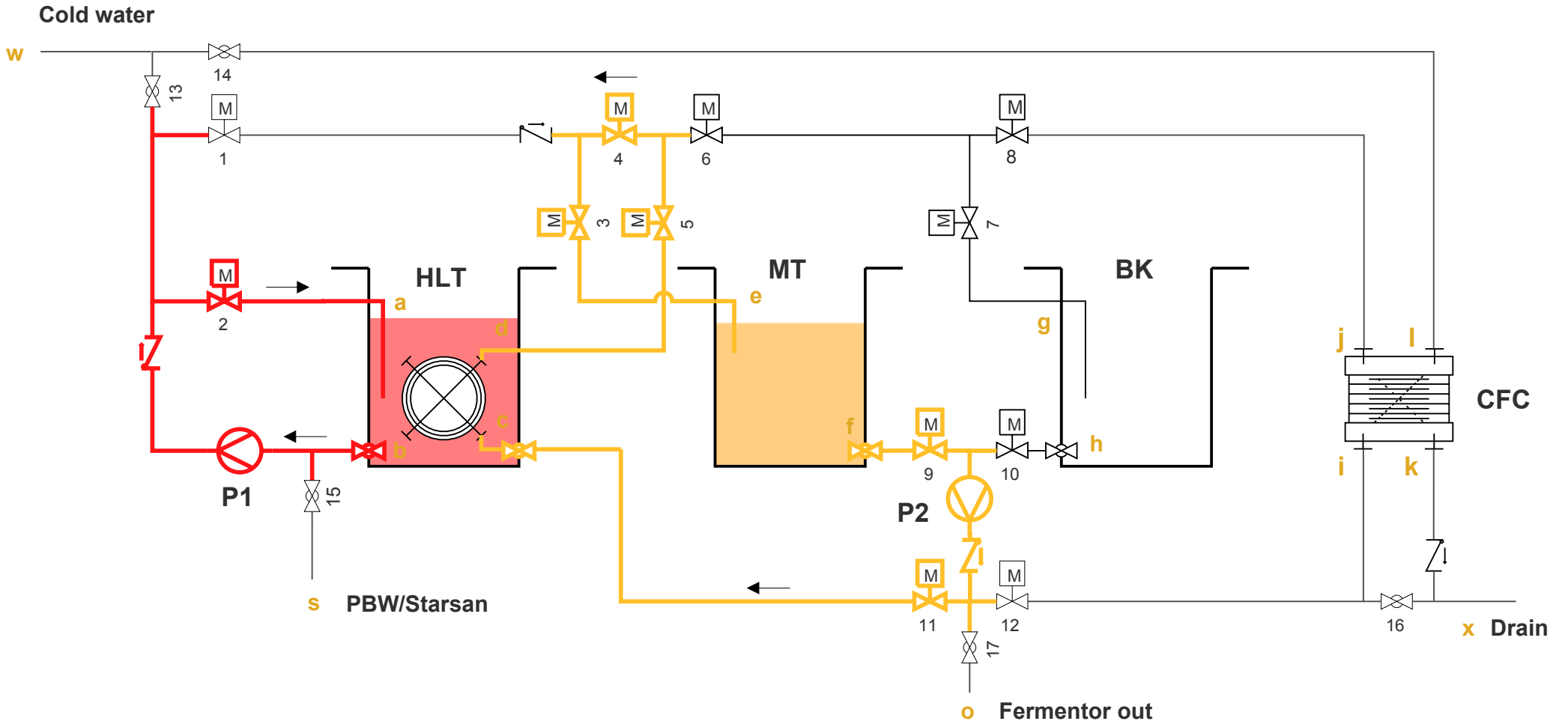

Mash
The mash is circulated by pump 2, through the coil in the HLT. By controlling the HLT temperature, the mash temperature is controlled. The HLT is circulated by P1.

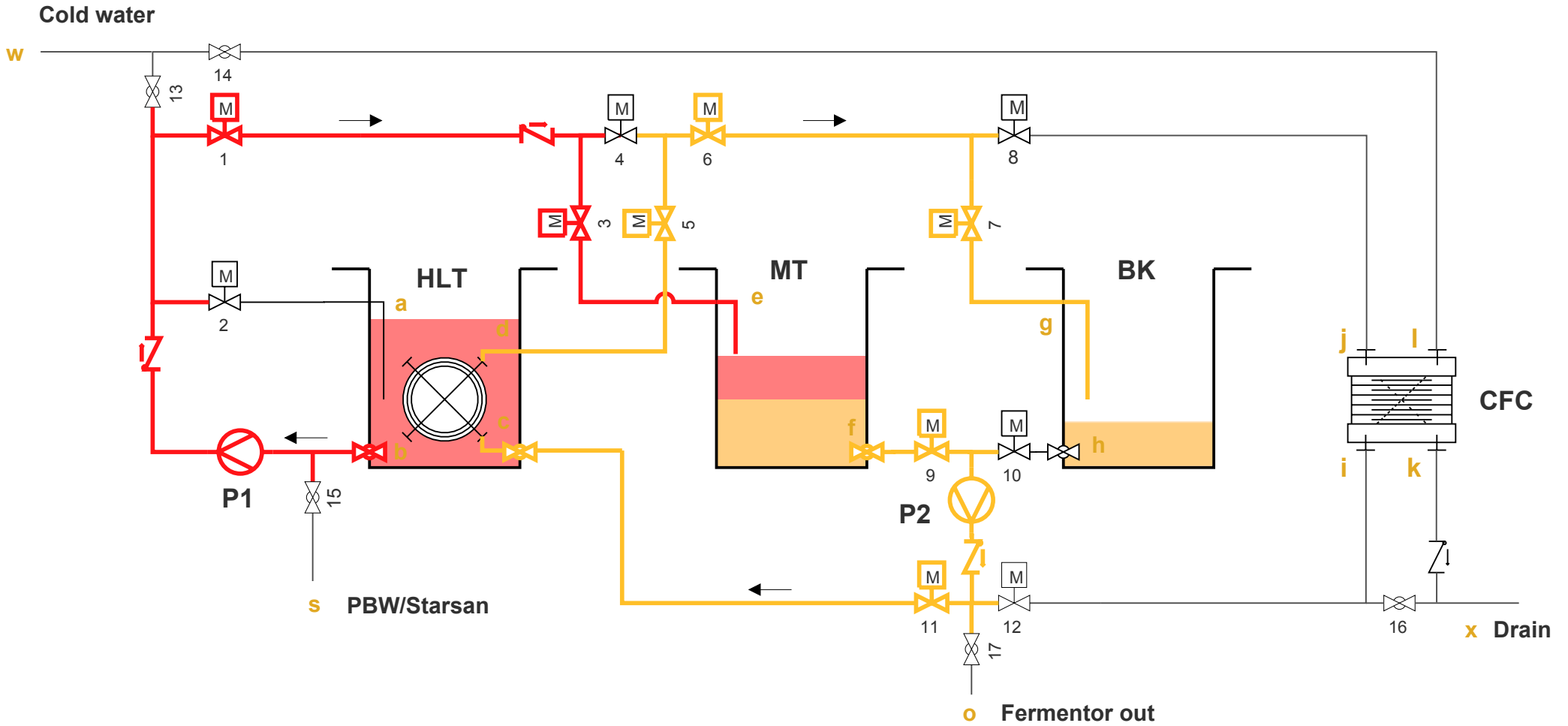

Sparge
Pump 2 pumps wort to the boil kettle via the coil. Hot sparge water from the HLT is pumped on top of the grains in the MT by pump 1.

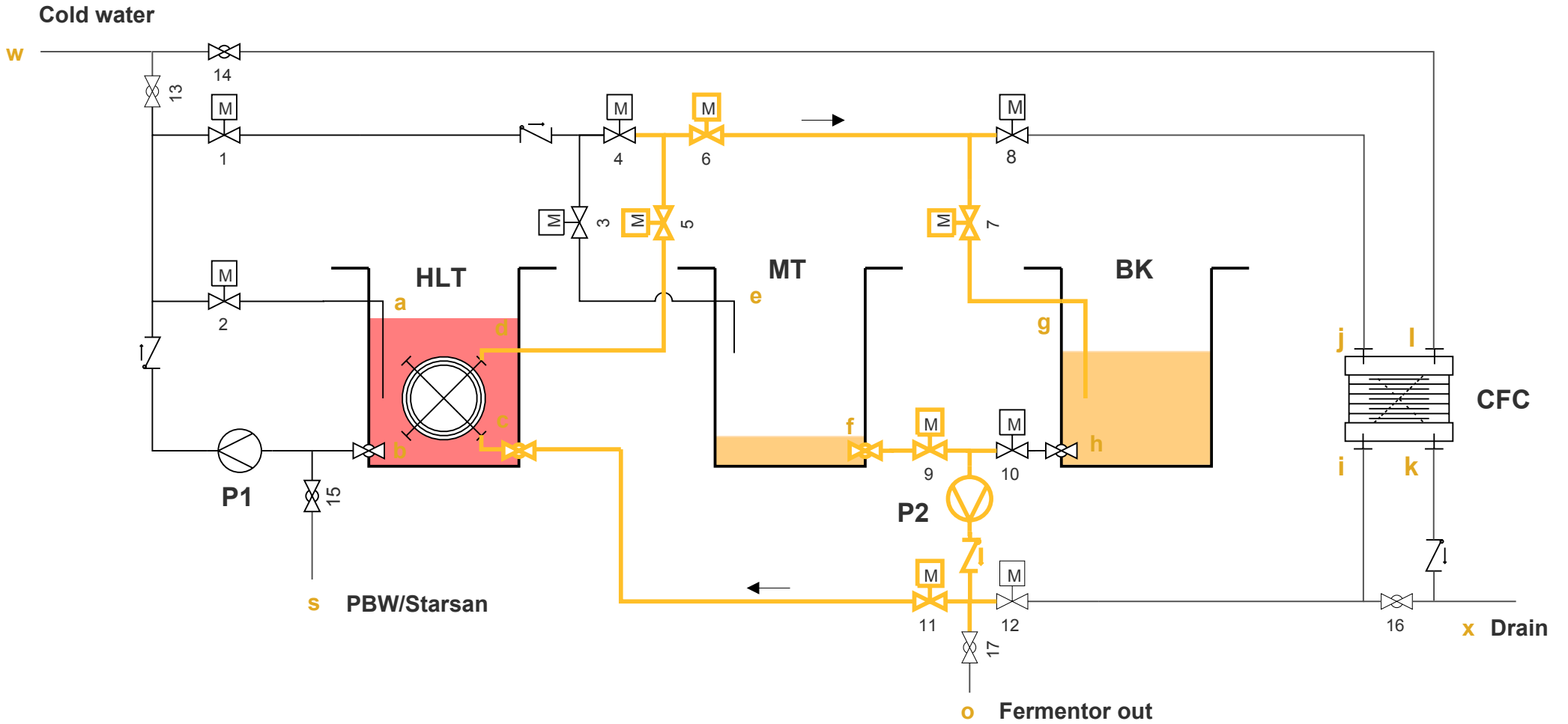

Sparge out

Pump 2 empties the mash tun into the boil kettle. When all the wort is in the boil kettle, all pumps are turned off and the boil is started.

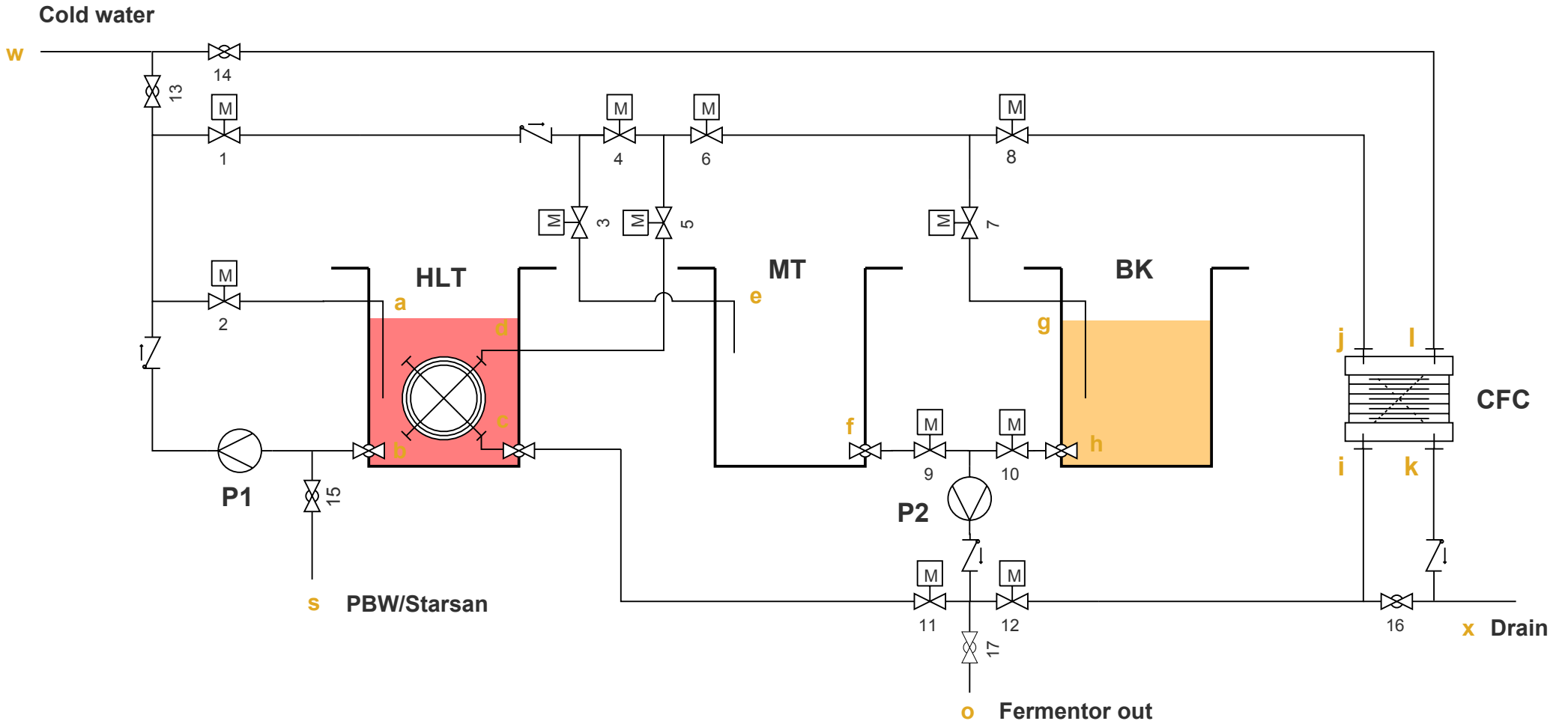

Boiling

No flows active during this step, but added it for clarity: wort is boiled! hops are added!

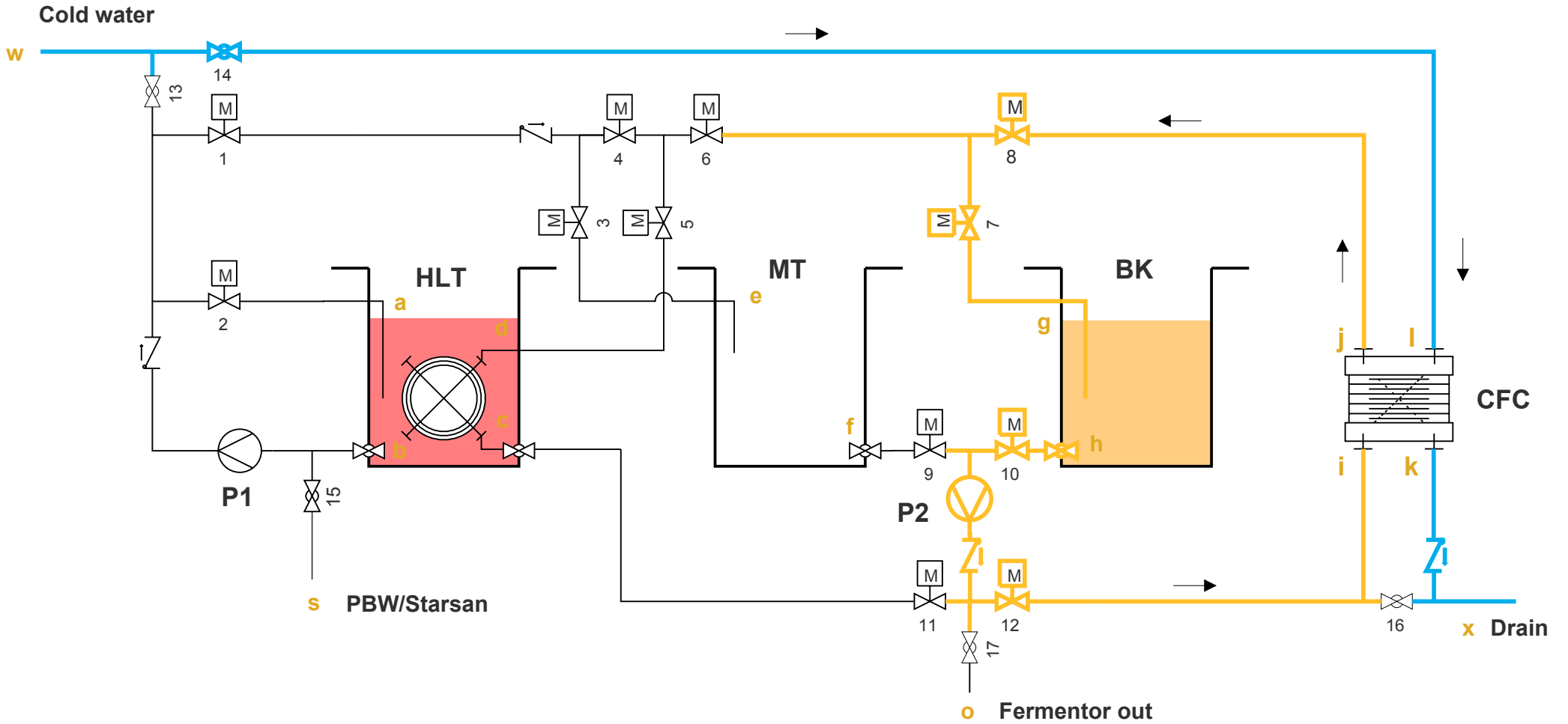

Cooling

After the boil the wort is circulated through the counter flow chiller until pitch temperature is reached. Valve 14 is manually opened to flow cold water through the CFC, but only after a few minutes of circulating boiling wort for sanitizing.

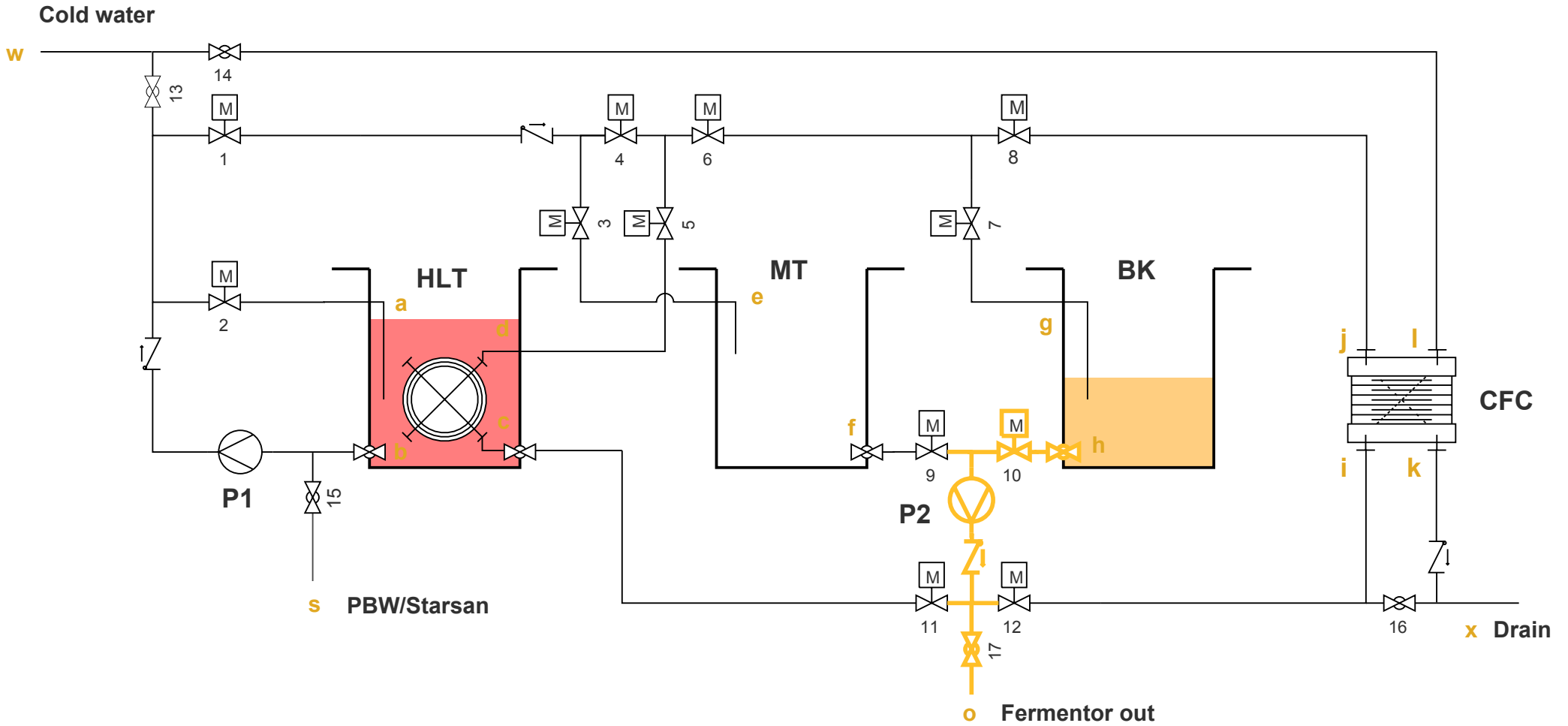

Wort to fermentor

After cooling, valve 17 is opened manually to pump the finished wort to a fermentor.

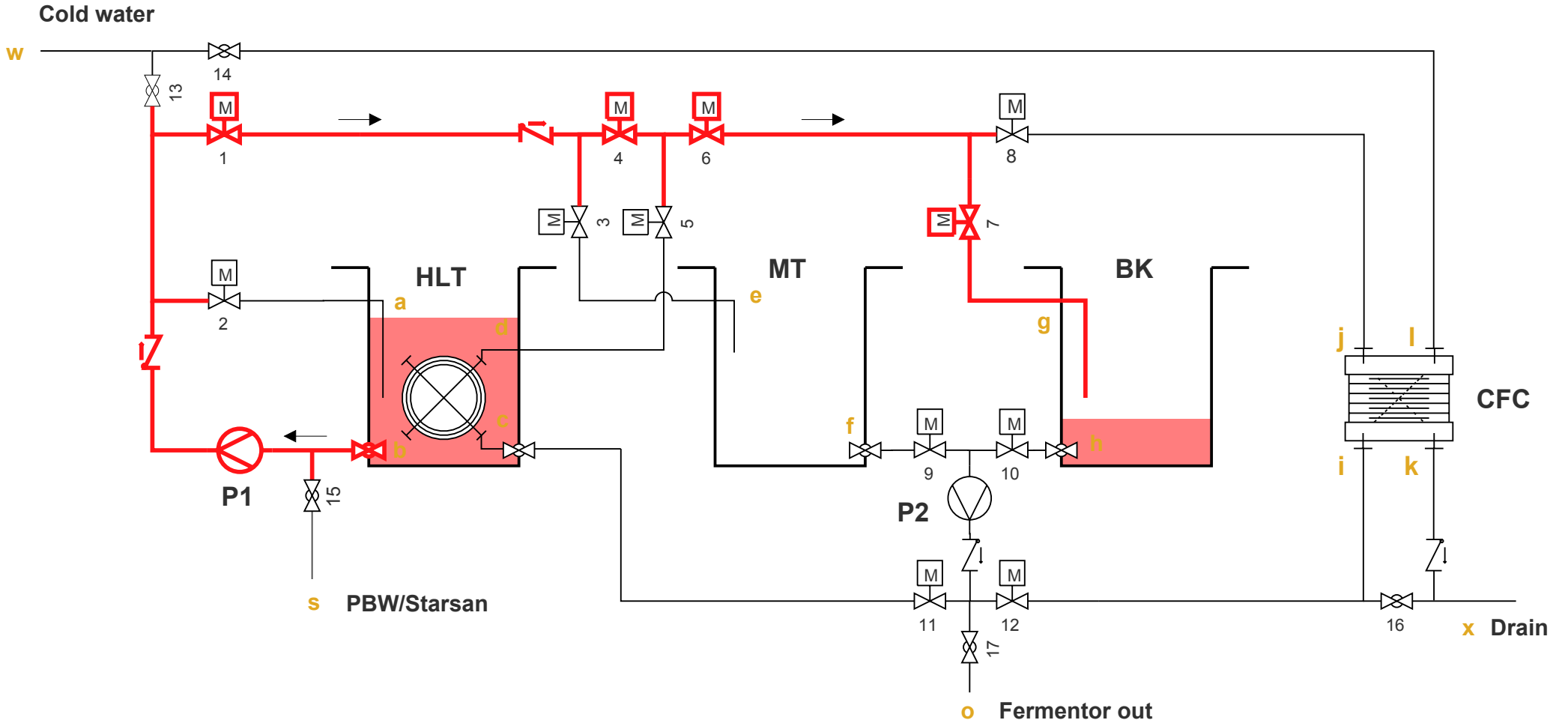

Extra sanitized water

If the volume in the fermenter is too low (due to not estimating evaporation correctly), it can be topped up with water from the HLT. The water has been heated and is sanitary. To use this, it has to be pumped to the BK first. Then the steps *cooling* and *to fermentor* are repeated.

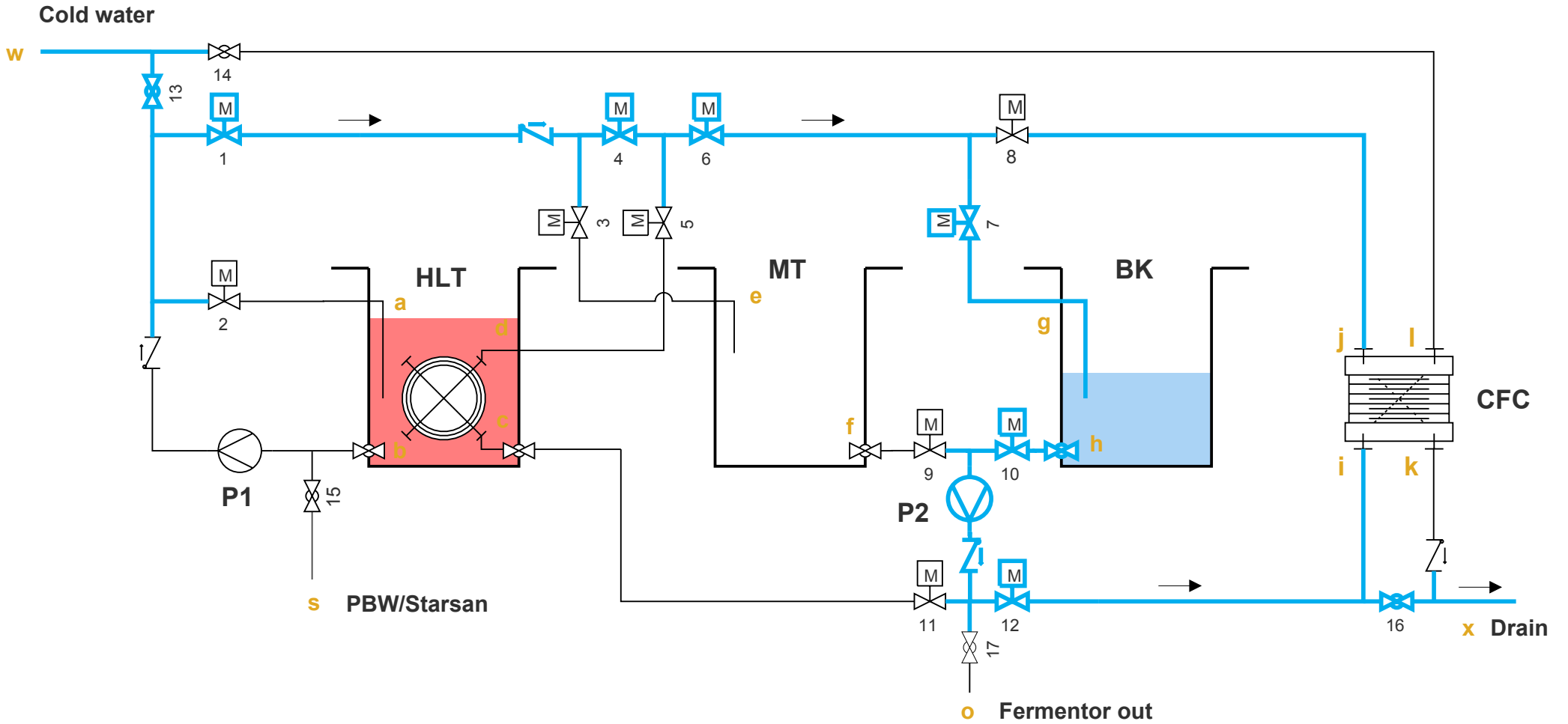

Clean in place 1:

Open valves 13 and 16 manually.
Flush boil kettle with cold water, by filling it with pump 1 and emptying it with pump 2.
note: no flow through valve 8.

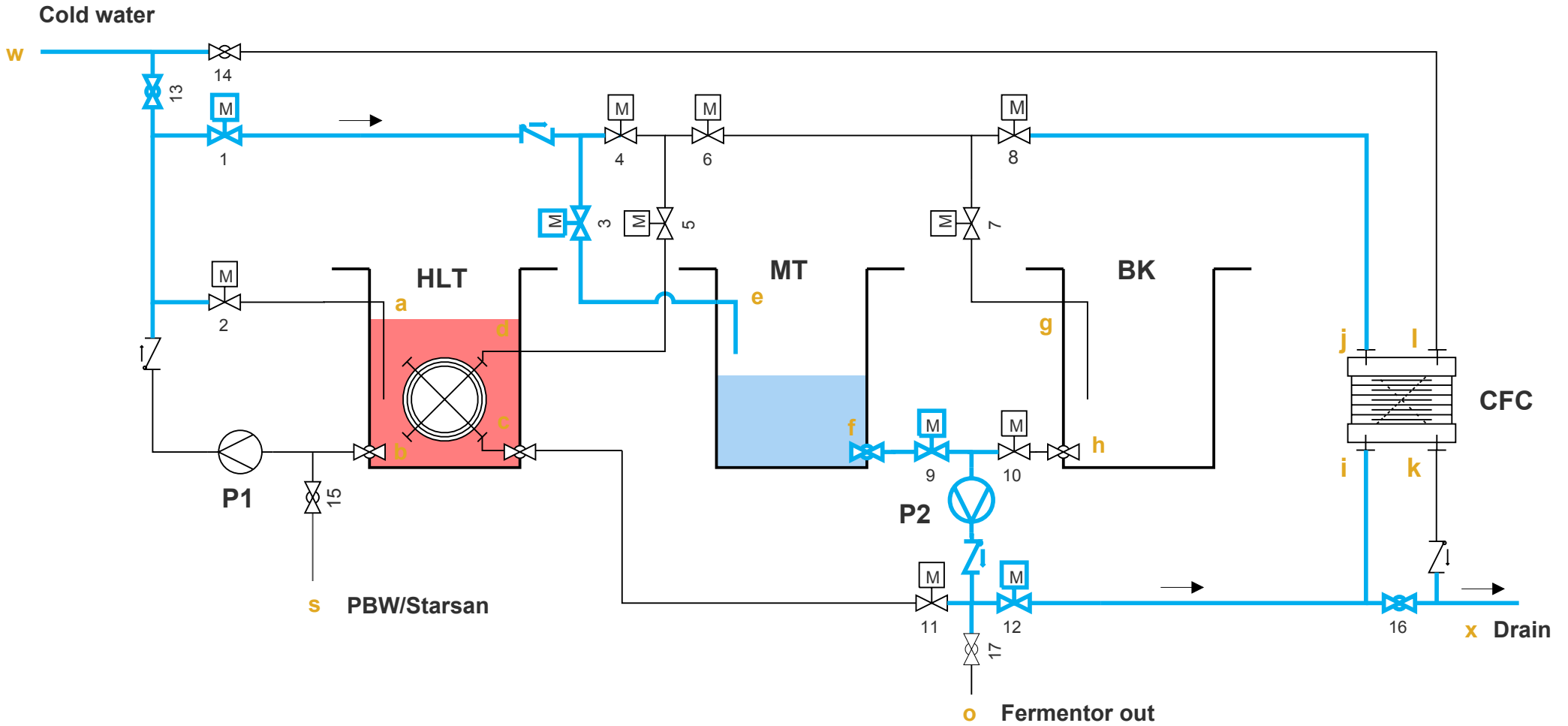

Clean in place 2:
Flush mash tun with cold water, by filling it with pump 1 and emptying it with pump 2.

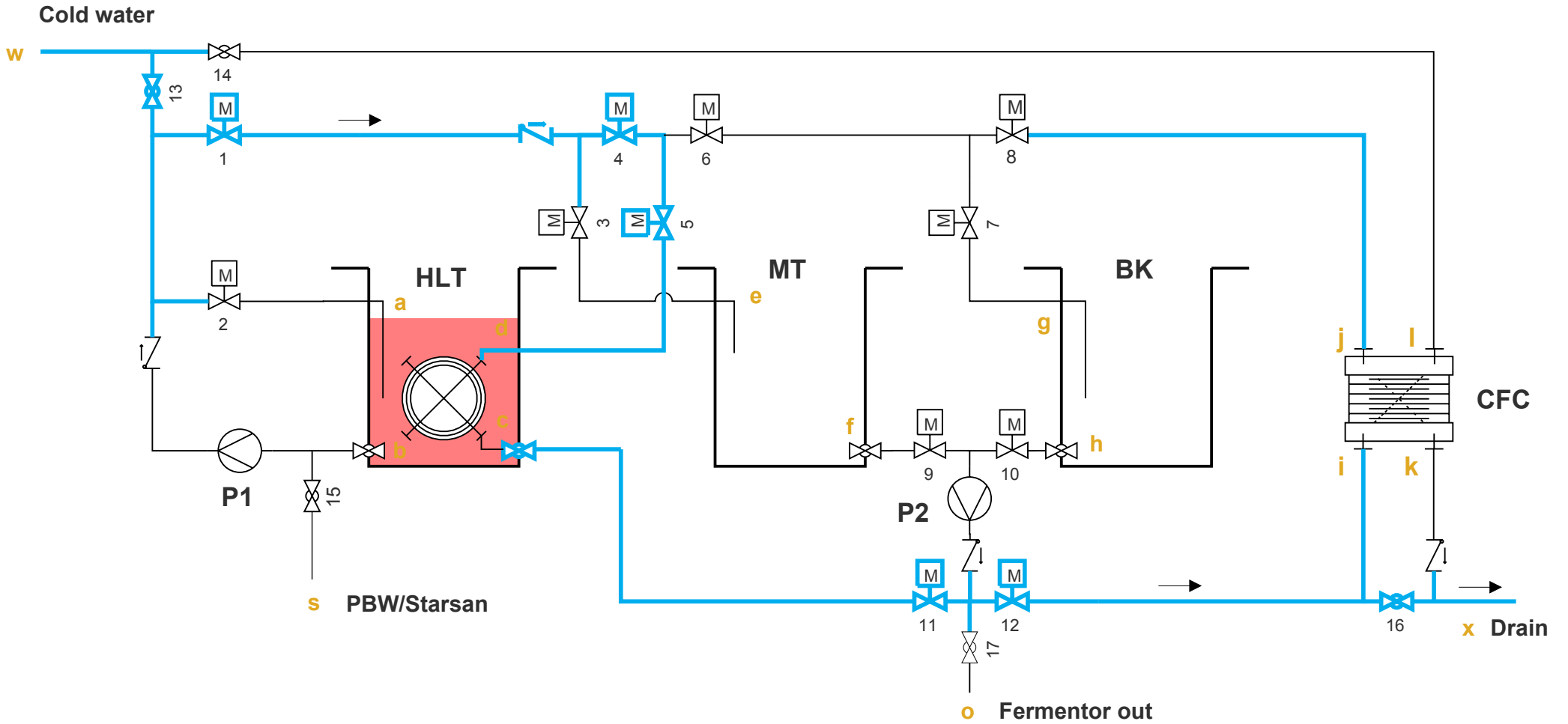

Clean in place 1:
Flush coil with cold water.

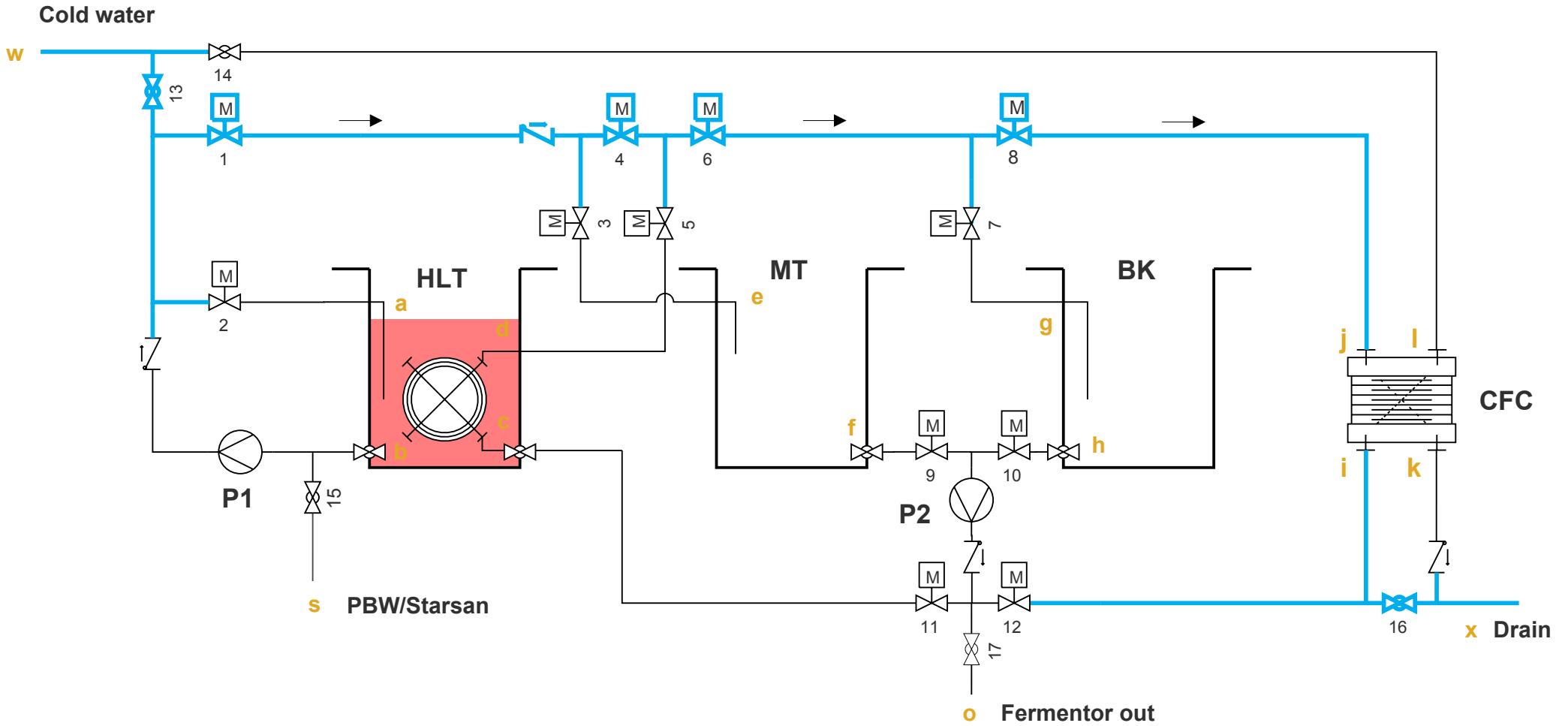

Clean in place 2:
Flush CFC (hot side) with cold water.

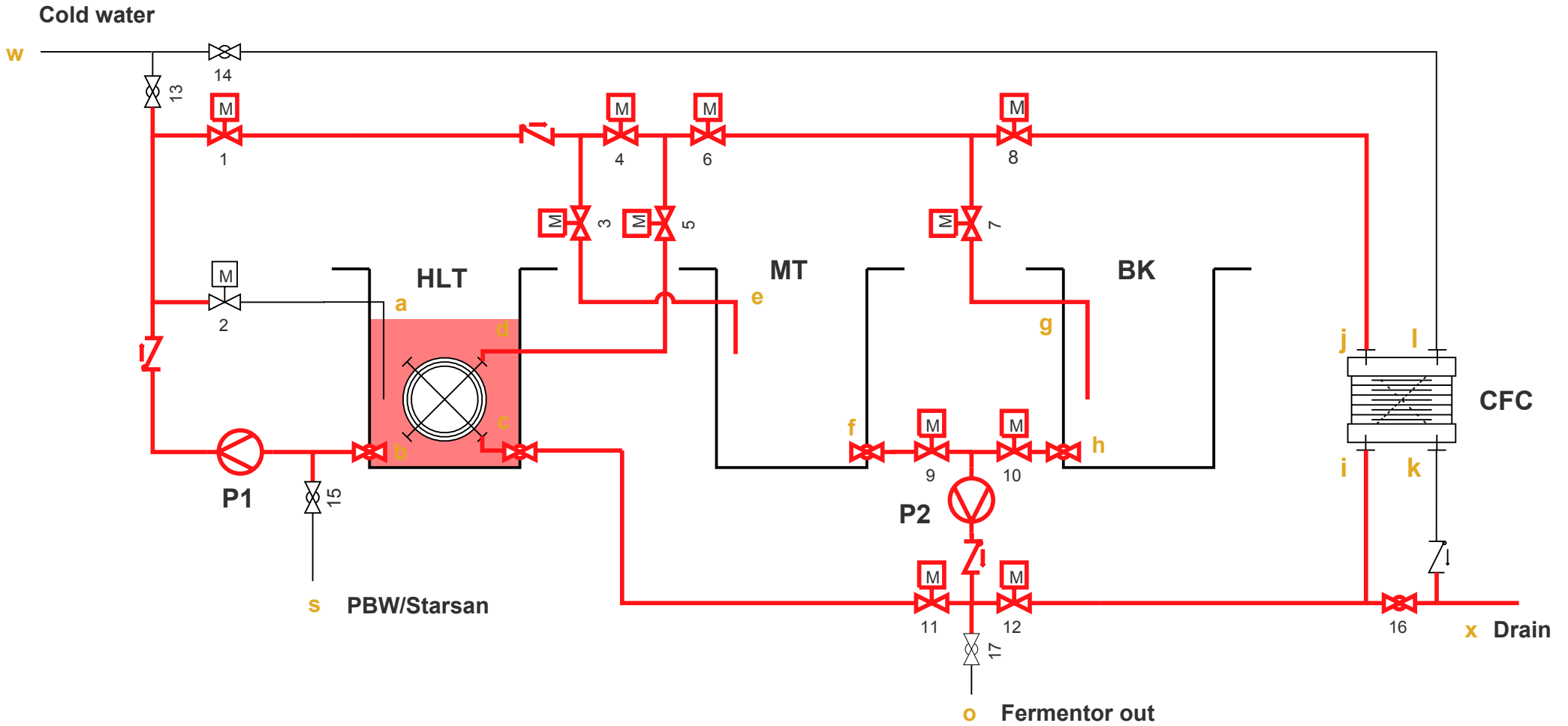

Clean in place: hot water

Clean in place step 1-4 can be repeated with hot water from the HLT.

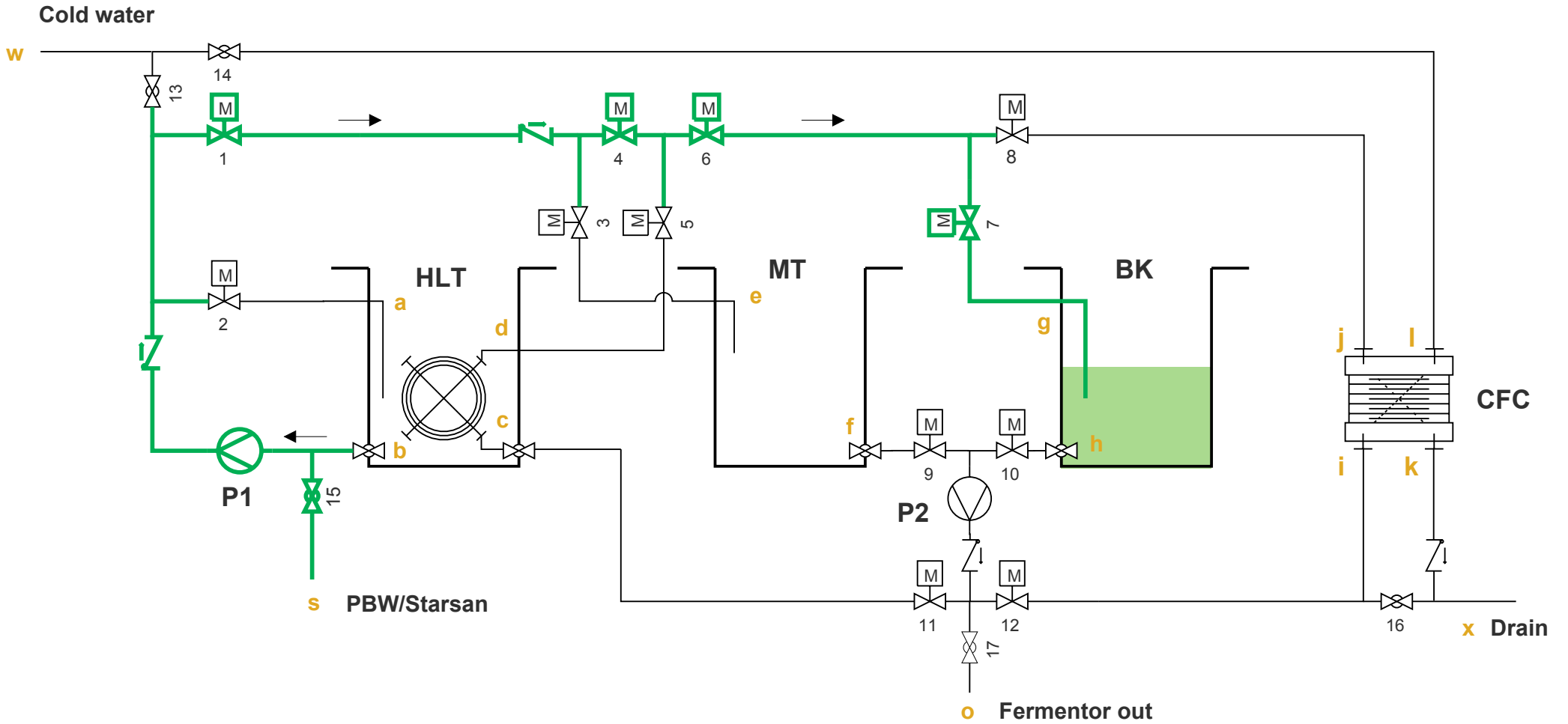

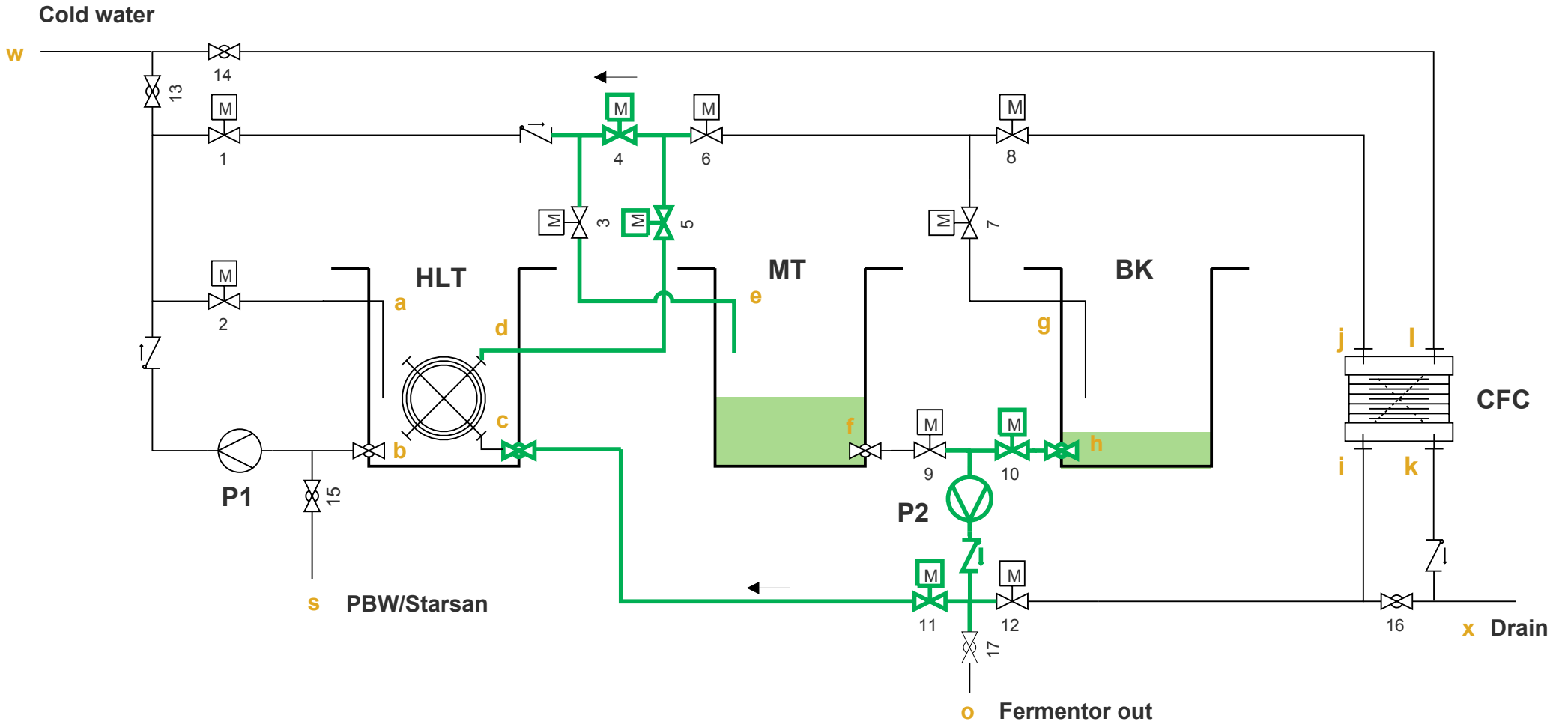

Sanitize/Clean step 2: sanitize HERMS coil and pump to Mash tun.
Sanitizer is circulated through the HERMS coil by pump 2.

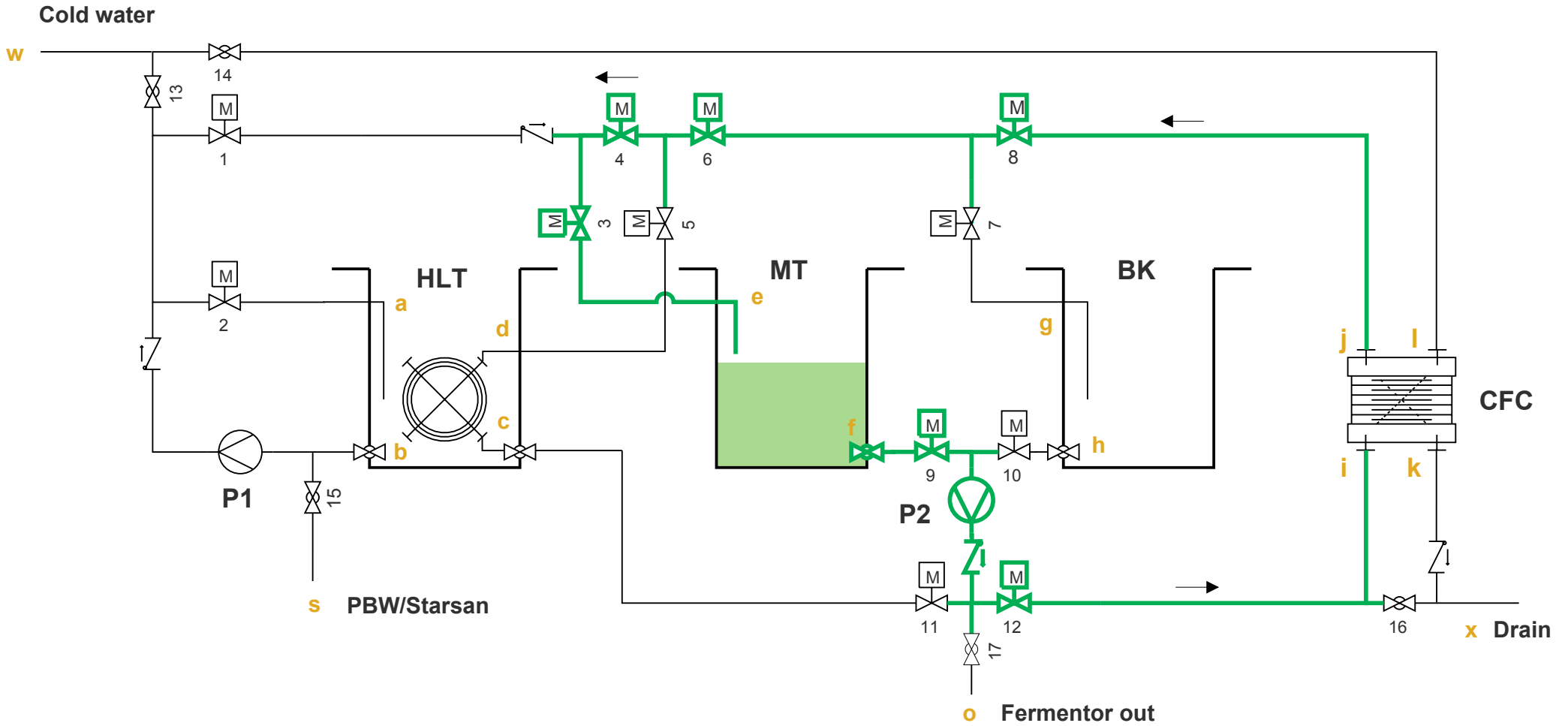

Sanitize/Clean step 3: Circulate through CFC
Sanitizer is circulated through the HERMS coil by pump 2.

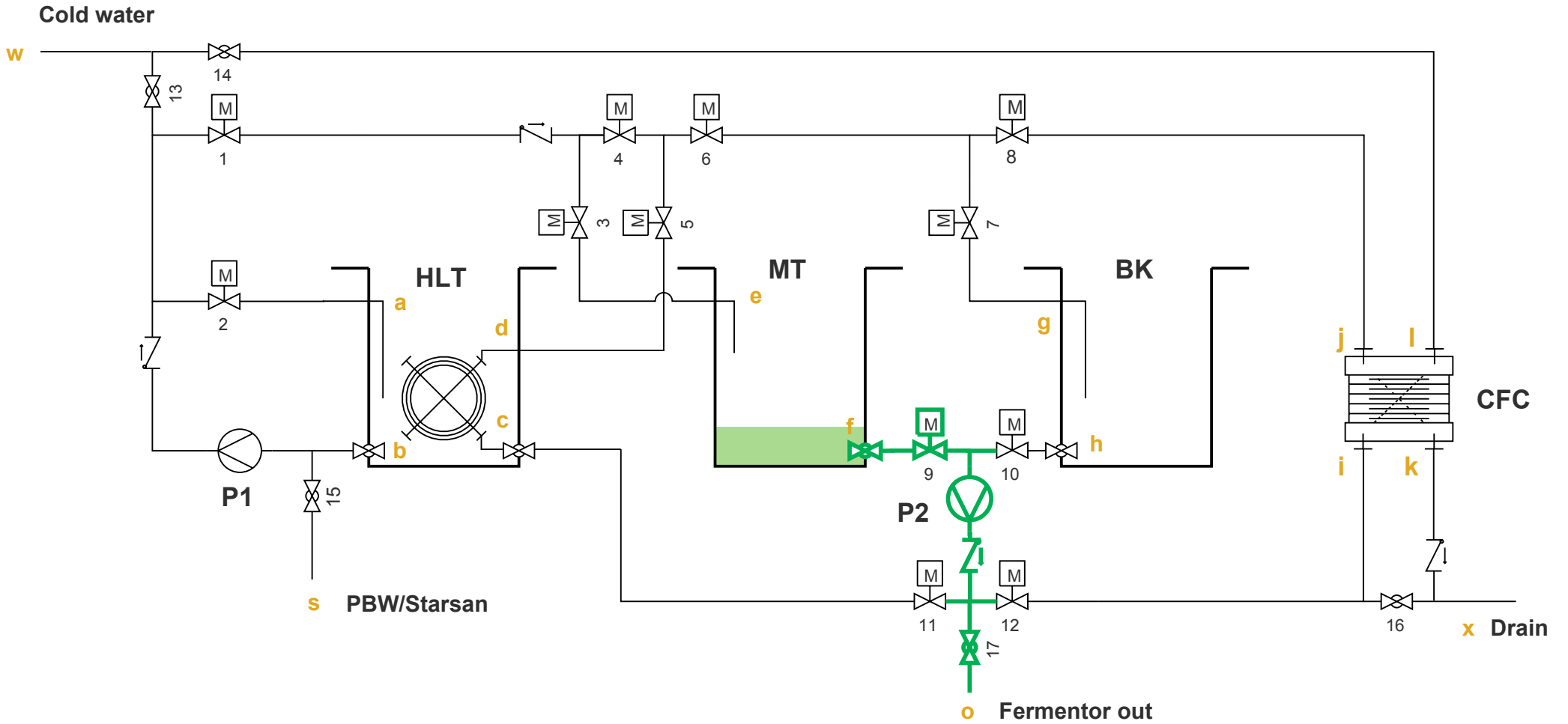

Sanitize/Clean step 4: sanitizer out

Pump sanitizer out via fermentor out. Catch it for reuse or dump it.